



COMMERCIAL

# Refrigeration Equipment 1-Glass Door Full Height Reach-In Back Room Refrigerator 31" Long

ITEM # \_\_\_\_\_

MODEL # \_\_\_\_\_

NAME # \_\_\_\_\_

SIS # \_\_\_\_\_

AIA # \_\_\_\_\_



738283 (KCHRI25R1GDR) 1-Glass Door Full Height Reach-In Back Room Refrigerator 31" Long

## Short Form Specification

**Item No.** \_\_\_\_\_

1 glass door refrigerator with exterior back and bottom panels in galvanized steel, exterior side and top panels in pre-painted steel; interior back, side, top and bottom panels in white High Impact Polystyrene. Control with cabinet temperature display. Self-closing door feature with lock and key.

Cabinet capable of accepting a full-size sheet pan (18X26).

R290 gas in the refrigeration circuit.  
ETL Safety and Sanitation certifications.  
3/5 Years warranty.

## Main Features

- External digital temperature display.
- Bright LED illumination, enhancing product visibility for impactful merchandising
- Removable gasket for easy cleaning operations.
- Fin & Tube Condenser improves performance in high temperature environments.
- Automatic Defrost Cooling System provides worry-free performance.
- Electronic Temperature Control, quick and simple to set, with control display for easy monitoring.
- Cabinet completely insulated with high density polyurethane for low environmental impact.
- Back bottom mounted cooling unit guarantee an easy access and cleaning.
- Heavy duty Vinyl coated steel shelves.
- Adjustable shelves for flexible storage
- On/off switch controls interior LED lights
- Cabinet capable of accepting a full-size sheet pan (18X26)
- Heavy duty vinyl coated steel floor protector shelves

## Construction

- Painted gray steel exterior, for durable and sleek finish
- White polystyrene interior, for high impact resistance
- Lockable door.
- Pre-wired heavy duty power cord.
- Heavy duty door hinges.
- Magnetic gasket removable without tools for easy cleaning.
- Adjustable leveling feet.
- Smooth rolling wheels, for effortless mobility

## Sustainability

- CFC and HCFC free, highly ecological refrigerant type: R290 (ecological gas in foam: cyclopentane). Hydrocarbon refrigerant gas R290 for the lowest environmental impact (GWP=3), to reduce green house and ozone depletion effects.
- High efficiency components to minimize the energy consumption still guaranteeing the highest performances.
- Hydrocarbon refrigerant gas R290 for the lowest environmental impact (GWP=3) - CFC and HCFC free.
- Interior LED light to save energy and for best internal visibility.
- 60 mm insulation for energy saving.

## Optional Accessories

- Shelf clips (4-pack) PNC 880611
- Shelf for 25 Cu. Ft. Reach-In PNC 880678

APPROVAL: \_\_\_\_\_

**Front**

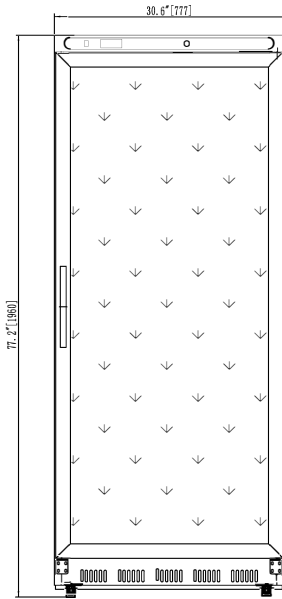

**Side**

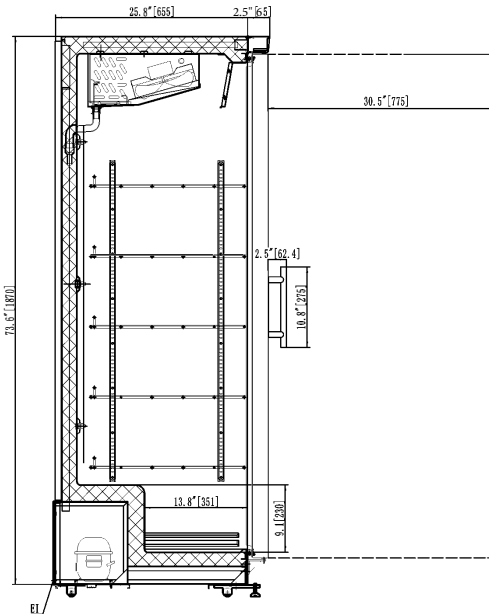

EI = Electrical connection

**Top**

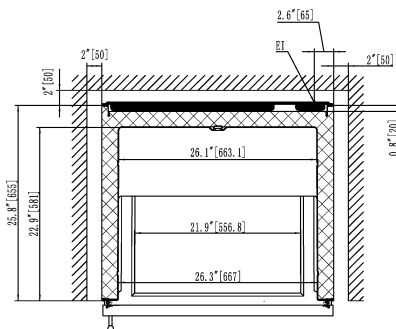

## Electric

Supply voltage:	115 V/1 ph/60 Hz
Electrical power, max:	2.07 kW
Plug type:	USA NEMA 5-15P

## Capacity:

Gross capacity:	22.7 cu.feet
-----------------	--------------

## Key Information:

Number and type of grids (included):	3+1 - Vinyl-Coated steel
Warranty:	3 / 5 years
Door hinges:	Right Side
External dimensions, Width:	30 9/16" (777 mm)
External dimensions, Depth:	28 3/8" (720 mm)
External dimensions, Height:	77 3/16" (1960 mm)
Number and type of doors:	1 Glass
Internal Dimensions (depth):	22 3/4" (578 mm)
Internal Dimensions (height):	65 3/8" (1660 mm)
Internal Dimensions (width):	26 3/8" (670 mm)
Shipping height:	82 11/16" (2100 mm)
Shipping weight:	324 lbs (147 kg)
Type of external material:	Prepainted Steel
Type of internal material:	High Impact White Polystyrene
Approvals	ETL C&US;ETL SANITATION

## Refrigeration Data

Condenser Type:	738283 (KCHRI25R1GDR)	Fin & Tube
Operating temperature min.:		32 °F
Compressor power:		1/5 hp
Operating temperature max.:		41 °F
Defrost type:		auto defrost

## Sustainability

Current consumption:	3 Amps
Refrigerant type:	R290
GWP Index:	3

Refrigeration Equipment  
1-Glass Door Full Height Reach-In Back Room Refrigerator 31" Long

The company reserves the right to make modifications to the products without prior notice. All information correct at time of printing.

